



NEXVISION'S PRODUCTS ECOSYSTEM
AEROSPACE - SECURITY - DEFENSE



EDITO



Hello all,

This catalog of optronic products is the fruit of passionate and exciting R & D work.

It represents today's ecosystem of comprehensive products in the sectors of defense, civil security and aeronautics, with a driving force in «situational awareness», which is to say, in the mixing of technologies in order to understand a situational environment in real-time wherever it may be (ground, sky, air, water, fog, night, snow, sand, wind etc.).

This is a need found in all types of autonomous vehicles (drones, robots, cars etc.), in civil security and obviously in the military, where the armed forces call for a technological advantage to win battles on the ground.

Nexvision puts all its know-how into these technically advanced, state of the art products. Our team of engineers pushes the limits on a daily basis to find breakthrough solutions for clients seeking solutions in their respective markets.

As master craftsmen in optronics, we produce small series products, made to measure, without any concession to quality.

You will find this scrupulous attention to detail in all our products.

Vincent Carrier, CEO Nexvision



SUMMARY



• **ABOUT NEXVISION** 4



• **ABOUT NIGHT VISION** 8



• **ABOUT SITUATIONAL AWARENESS** 12



• **NEXVISION'S PRODUCTS ECOSYSTEM** 16



• **PROCESSING UNIT** 18



• **PORTABLE VIEWER** 24



• **PANORAMIC CAMERA** 28



• **HEAD MOUNT DISPLAY** 32



• **GYRO POD** 38



• **MODULAR CAM** 46



• **SPOT LIGHT** 54



• **VMS / C4-ISR** 60



• **QUALITY MANAGEMENT SYSTEM** 64

ABOUT NEXVISION

A GLOBAL EXPERTISE ON THE WHOLE VISION SYSTEM CHAIN AND A SHORT INTEGRATION PROCESS OF LATEST TECHNOLOGIES !

NEXVISION is an independant, innovative and successfull design house for electro-optics systems.

Exploration of new technologies is our DNA, and we integrate the entire design and integration scheme in our core activity.



DEFENSE
& SECURITY



AEROSPACE



INDUSTRIAL
INSPECTION



MEDICAL

A global integrated expertise on the whole electro-optic vision systems chain:

From FPGA electronic design to mechanical and optical design along with embedded vision software, NEXVISION covers all technics with an agile team able to integrate a transversal expertise in a global approach.

Early adopter for Nvidia embedded processors, Microoled displays and Photonis image sensors:

NEXVISION is one of the rare companies in the world to get an official technical support of Nvidia's Tegra media-processors (K1, X1, etc.) and of Photonis's new image sensors (SCMOS, EBCMOS, iCMOS).

A large spectrum of technological survey:

NEXVISION is able to identify world technical innovations in vision applications from new components, algorithms, publications and concepts and react quickly to integrate new technologies to its expertise pool.

NEXVISION AT A GLANCE

- A team of **30** engineers
- **20** years of existence and innovation
- **6** expertise pools : electronics, logic design on FPGA, optics, mechanics, embedded software & computer vision
- **25** core technical expertises
- A presence in **4** continents (North America, Europe, Africa, Asia)

A technology explorer:

NEXVISION's DNA is to test non-mature technology every time it is possible and to assess their potential. We learn how to master it to be able to propose them to our clients without any risk (Terahertz, LiDaR, SLAM, Fusion, HMC Memory, NVMe, EBCMOS imaging, OLED display, range gating...)

A permanent support for our clients' technical key issues:

Research with our customers to identify their root needs and the best appropriated integrated solution. We go beyond the business mode of a design house by bringing to our customers our global optronic approach to their specific needs.

A high reactivity level of experts:

With the integration of all expertise in a human sized organization, our teams are able to find a solution quickly and efficiently.

KEY PARTNERS



PHOTONIS



OUR DESIGN HOUSE

YOUR BEST PARTNER TO DESIGN HIGH-END INNOVATIVE VISION SYSTEMS

For more than 18 years, we have been designing highly innovative vision systems for major clients with our most advanced technology to allow them to keep one step ahead with a lower risk.

We are an outsourced R&D office for big companies.

CLIENTS



R&D without risk

« To integrate a non mature but promising technology in our system is always a risk. NEXVISION with its explorer temperament allows us to assess the viability of a new option by testing it themselves first. Then, we can be sure that what they propose is beyond the state of the art and functional. That really makes the difference. »

A helicopter manufacturer

Time to market : to be the first

« We had a project that would have cost us 2 years of development. With NEXVISION expertise and agility, we gain a whole year of development, and a reduction of 50% of our cost. When you want to be the first on the market, NEXVISION is a major asset. »

A world leader in optronics for defense market

Multiple high level expertises

« Optronic systems require multiple high level expertises for limited time. As NEXVISION masters the whole conception and integration chain, we know we can find what we need when we call them. »

A world leader in aerospace equipment

OUR PRODUCTS

A RANGE FOCUSED ON SITUATIONAL AWARENESS

Nexvision also develops its own range of products centered on situational awareness. Designed mainly for defense and security applications, these products carry the best of our know-how and the latest technologies straight out of the laboratories.

Keywords:

- Night vision
- Panoramic vision
- Augmented reality
- Multispectral gyrostabilized gimbal
- Laser projector
- Sensor fusion



A COMPLETE IMAGE PROCESSING & ANALYSIS ALGORITHM'S LIBRARY

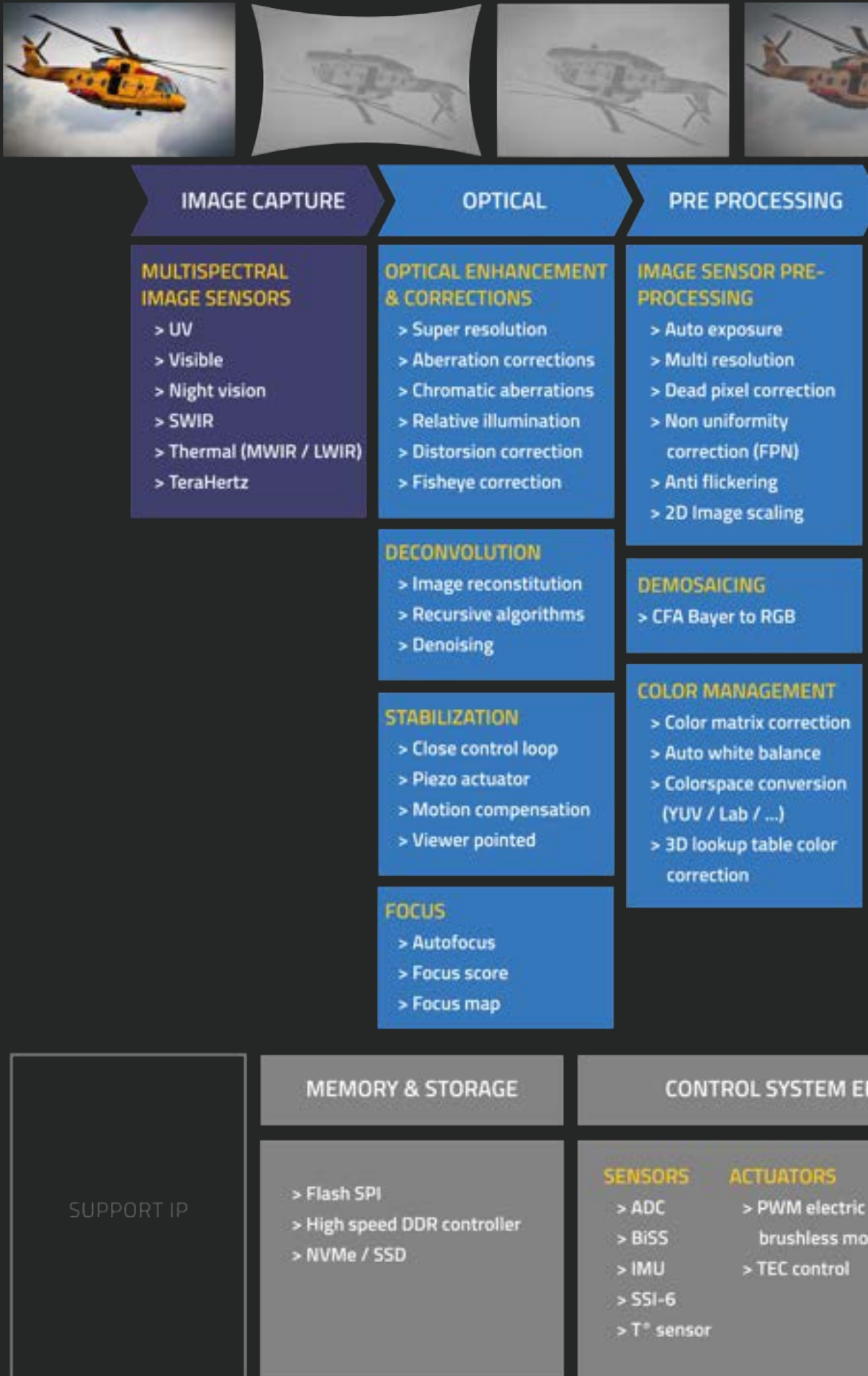



ANALYSIS RESULTS

- ⊕ Type : Helicopter
- ⊕ Color : Yellow
- ⊕ Speed : x pixels/s
- ⊕ ...

ENHANCEMENT

ANALYSIS

DYNAMIC RANGE

- > High Dynamic Range
- > Dynamic local tone mapping

FILTERING

- > 3D noise filter
- > Contrasts & edges enhancement
- > Spatial filters
- > Median filtering

DETECTION / RECOGNITION

Methods

- > Feature extraction
- > Pattern matching
- > Texture recognition
- > Optical Character Recognition
- > Smart line detection (rail, lane, path, horizon)
- > Multispectral band object recognition
- > Content based image retrieval

Applications

- > Suspicious stationary object detection
- > Motion detection
- > Number plate recognition
- > Traffic accident detection
- > Streetcar line detection
- > Fire detection
- > Pedestrian counting
- > Human body detection
- > Gesture recognition

TRACKING

- > Online tracking
- > Specialized trackers
- > Autonomous tracking initialization

MACHINE LEARNING

- > Deep learning
- > Neural networks

ENVIRONMENT MEASUREMENT

- > Augmented reality
- > SLAM
- > 3D scene reconstruction
- > Localisation / positioning
- > Advanced Driver Assistance System
- > Ground speed estimate
- > Unified scene alignment
- > Depth map
- > Sensors fusion
- > Stitching
- > Barcode / QR Code reading
- > 1D, 2D, 3D measurement

ENGINEERING

COMMUNICATION

VIDEO OUTPUT

CONTROL LOOP

- > PID
- > Park / Clarke
- > Filters

AXI INFRASTRUCTURE

DATA / SERIAL INTERFACE

- > PCIe (FPGA to SoC DMA)
- > USB 2.0, 3.0 & 3.1
- > NVMe / SSD
- > Fiber-optic interconnect

I/O

- > Composite
- > HDMI
- > SDI (3G-HD)
- > CoaXPress
- > Camera Link

OVERLAY / OSD

- > Painting
- > Apply

DISPLAY

- > Microoled
- > LCD

SEE WITHOUT BEING SEEN

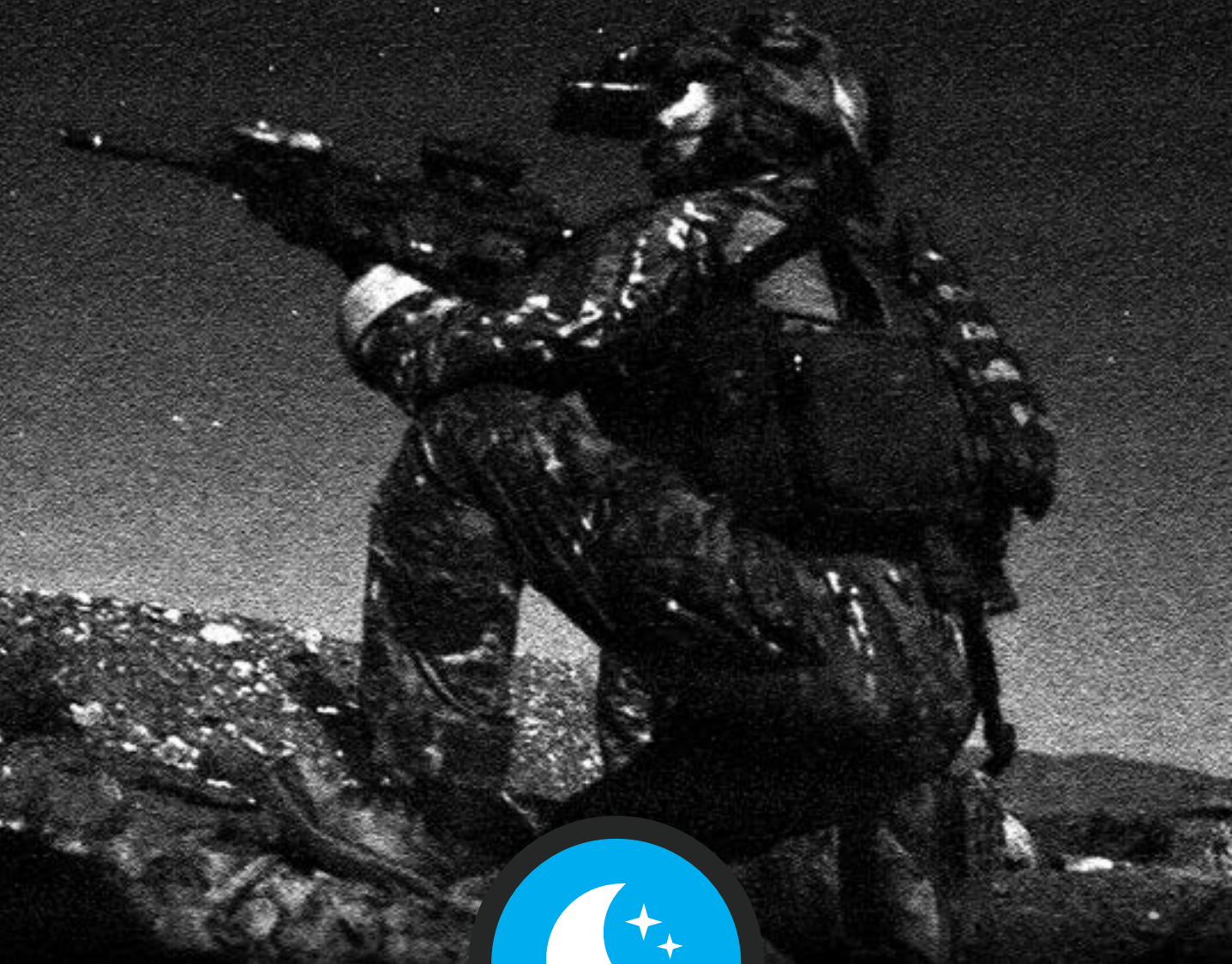

ABOUT NIGHT VISION

To see by night is a relevant need in particular for special forces which operate by night and must take the advantage on the enemy, as well as helicopter pilots in degraded visual environment (DVE).



DAYLIGHT



Dark limit of civil twilight under a clear sky
More than 1 Lux



LEVEL 1



Full moon on a clear night
40 mLux to 1 Lux



LEVEL 2



Full moon on a cloudy sky
10 mLux to 40 mLux



LEVEL 3



Quarter moon
2 mLux to 10 mLux



LEVEL 4



Dark, moonless, night sky (starlight)
0.7 mLux to 2 mLux



LEVEL 5



Very dark, moonless, overcast night sky (starlight) «can't see your hand in front of your face»
100 μ Lux to 700 μ Lux



LEVEL 6



Deep dark
< 100 μ Lux

NIGHT VISION

WE OPERATE THREE MAIN NIGHT VISION SENSORS

NATO NIGHT LEVEL : up to 5

S-CMOS SENSORS (LVL 3)

EB-CMOS SENSOR (LVL 5)



LYNX
Black & white
1.3 Mpx



KAMELEON
Color
1.3 Mpx



EBCMOS
Black & white
1.3 or 4.2 Mpx

PHOTONIS



HD sport Camera



Uncooled Thermal Camera



EBCMOS Camera





TECHNOLOGIES REVIEW

Whereas the NVG (Night Vision Goggles) show their limits (weight, reduced field of view, analog image, weak resolution,...), new generation digital sensors make it possible to open a wide field of possibilities (better resolution, color, fusion of information, augmented reality, multi-spectral, noise filter, digital zoom, transmission, recording...).

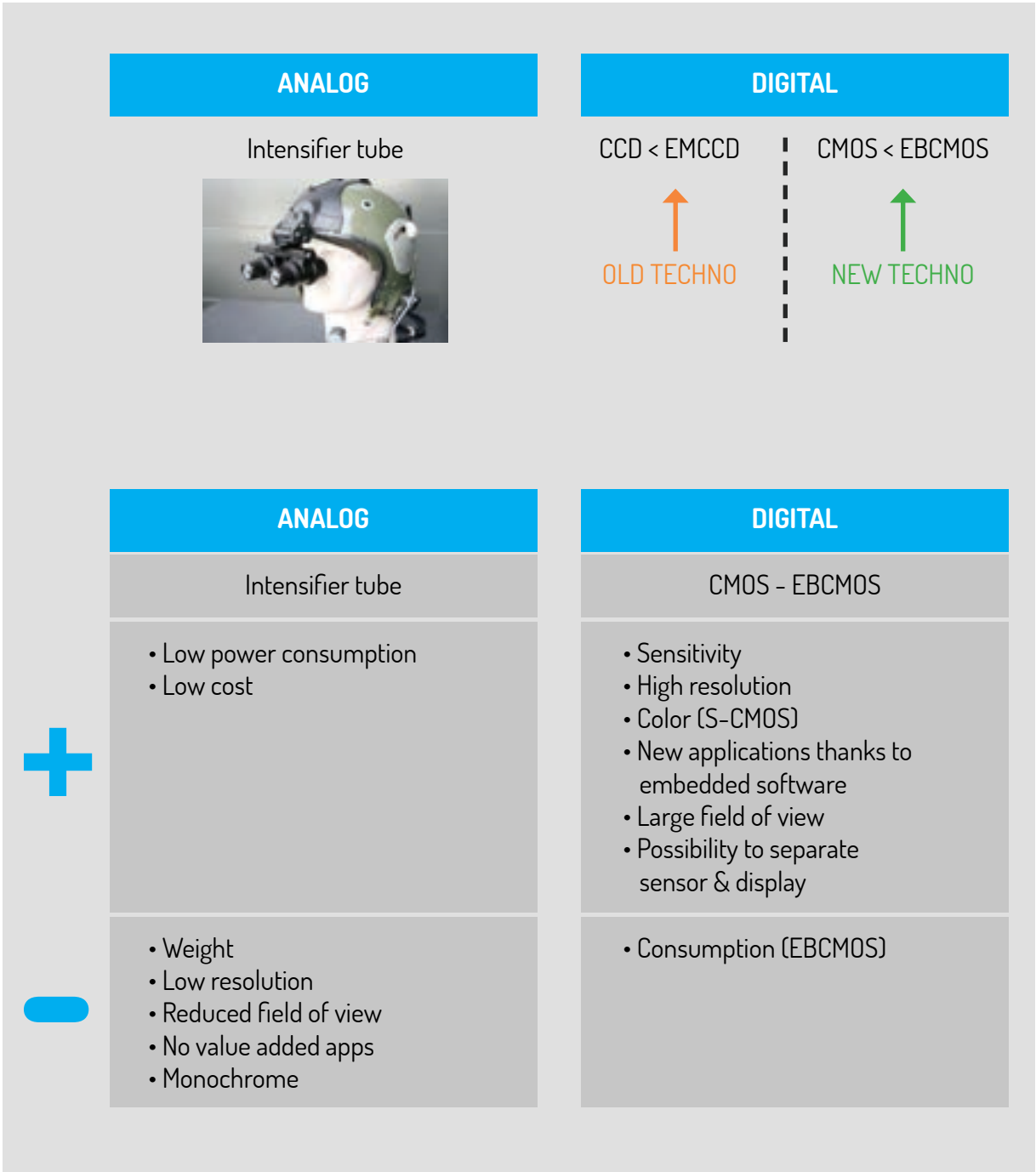



ABOUT SITUATIONAL AWARENESS

UNDERSTANDING THE ENVIRONMENT WHEN THE VISIBILITY IS REDUCED



SAND / DUST

FOG

SNOW

NIGHT



What is « situational awareness »?

It is an aid in the perception and awareness of an environment.

This includes a combination of three elements:

- Sensors with very wide fields of perception
- A sensor's information analysis algorithm
- A machine with a user-friendly and ergonomic interface presenting the results of these analyses.

What is « situational awareness » for?

It allows a person to apprehend their immediate and surrounding environment, with a performance superior to that which their own senses can achieve in real-time, helping them to react and interact whilst performing a mission.

Furthermore, the «situational awareness» function of the machine is at the core of its autonomy during complex missions (i.e. autonomous land, air and sea vehicles, drones, robots working in outdoor environments etc.)

What type of technology is necessary?

To get good perception in all types of extreme situations, a single type of sensor technology is not enough. The «situational awareness» function uses new types of miniaturized ultra-high-performance sensors (solid-state radar, active lidar / ToF depth camera imaging, night vision, throughfog imagers, thermal and near-infrared sensor, hyperspectral imagers, high-speed imagers) and sophisticated artificial intelligence analysis algorithm calculators (GPU/CPU, neural processor, FPGA).

Why Nexvision got involved in « situational awareness »?

It was a natural progression. The intelligent perception of the environment is the technical basis of our market. With the rapid evolution in this type of technology, especially in terms of computing power, the possibilities today for applications based on vision systems are enormous and will only increase in the future. Over the course of our R & D projects, Nexvision has structured itself in such a way that we now have all the necessary skills in-house to build complex, tailor-made vision systems based on one or multiple image sensors whilst developing the entire system going with it; whether it be in electronic embedding (hardware, software - including image processing and analysis algorithms), but also optical and mechanical systems, with strong expertise in the fields of aeronautics, defense, security and transport.

What are the key success factors?

Technical performance, quality assurance, ergonomics and price.

How will this evolve in the years to come?

This will result in an explosion in the complexity and performance necessary for even more autonomous systems and robots; being that people will always seek to go faster and deal in more extreme conditions. Intelligent sensors for environment assessment must therefore follow this evolution; for without this, these robots will not be able to operate.



OUR SOLUTION TO ENHANCE VISIBILITY & UNDERSTAND THE ENVIRONMENT

FUSION OF 3 SENSING SYSTEMS

#Identify

PROXY VTOL 30m

Sensor #1 : Flash LIDAR

Active imaging / VNIR band

Sensor #2 : Millimetric RADAR

Sensor #3 : Panoramic Video Camera

Color sensor / Visible band

#Recognize

APPROACH VTOL 100m

Sensor #1 : Flash LIDAR

Active imaging / SWIR band

Sensor #2 : Millimetric RADAR

Sensor #3 : Infrared Camera

Thermal sensor / LWIR band

#Detect

SENSE & AVOID 500m

Sensor #1 : LIDAR

Time of flight (ToF) / SWIR band

Sensor #2 : Infrared Camera

Thermal sensor with zoom / MWIR band

Sensor #3 : Video Camera

4K night sensor with zoom / VNIR band

PROCESSING & ANALYSING UNIT

AI / Augmented reality

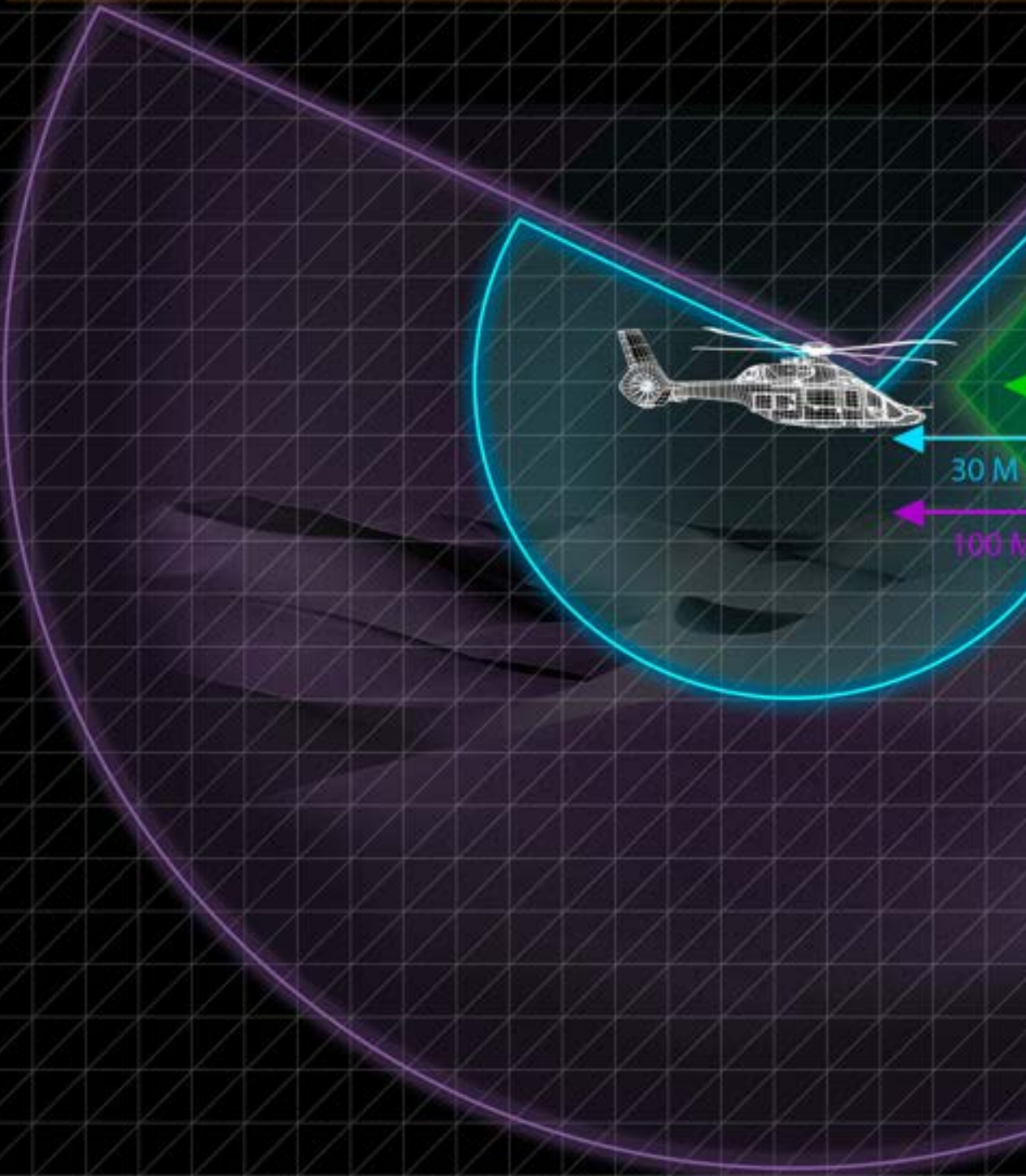

ENVIRONMENT IN CASE OF DVE [Degraded Visual Environment]

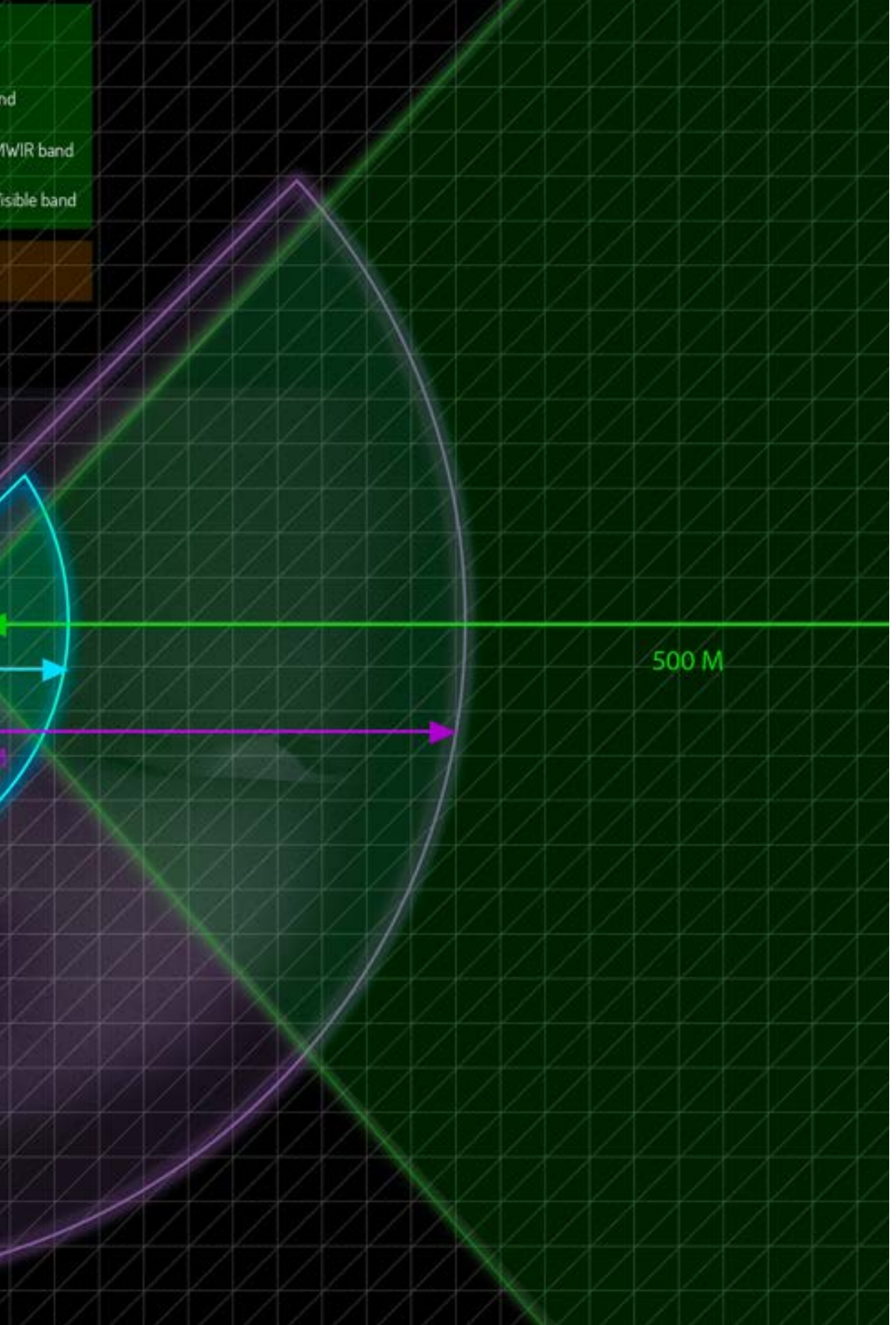

NEXVISION'S PRODUCTS ECOSYSTEM



PANOMIX
Panoramic camera
(120°, 180° or 360°)



EXTREM OWL
Augmented reality helmet

VPU

High performance
video processing unit



GSG 11

Dual band day / night
gyrostabilized gimbal



MOOVCA

High performance
video camera



DIGITOWL

Night vision hand
held imager



NVS-11

Augmented reality helmet

AEROSPACE - SECURITY - DEFENSE

VPU
High performance video processing unit

SLBS
Scanning Laser Beam Searchlight

CLBS
High power laser projector

PANOSPOT
360° HD video camera + gyrostabilized multispectral zoom

VMS
Command and control center

NEXVISION

A RANGE OF PRODUCTS
FOR NEW BATTLE FIELD SITUATIONAL AWARENESS



PROCESSING UNIT



FOR AN EVS/EFVS (Enhanced Vision System/ Enhanced Flight Vision System), YOU NEED HIGH COMPUTING POWER FOR IMAGE PROCESSING, IMAGE ANALYSIS AND DATA FUSION.

SO, WE DESIGN EVPU : A POWERFUL PROCESSING PLATFORM READY-TO-CUSTOMIZE FOR HIGH-END EMBEDDED VISION SYSTEMS.

EVPU is perfect for vehicle, autonomous or not, in extreme conditions [#DVE - Degraded Visual Environment].

eVPU : EMBEDDED VISION PROCESSING UNIT

POWERFUL COMPUTING PLATFORM FOR DATA FUSION, IMAGE PROCESSING & ANALYSIS (detection, tracking...)



For :



Autonomous tractor
Smart Farming



RPAS/UAV
Unmanned Aerial Vehicle



USV
Unmanned Surface Vessel



Aircraft/VTOL
Vertical Take off & Landing



AUV
Autonomous Underwater Vehicle



Tank/train/bus/trucks/UGV
Unmanned Ground Vehicle

Applications :

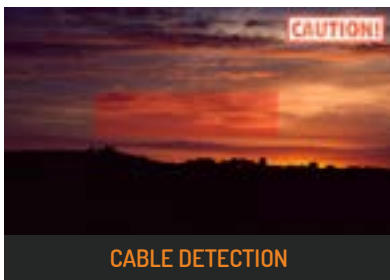

CABLE DETECTION

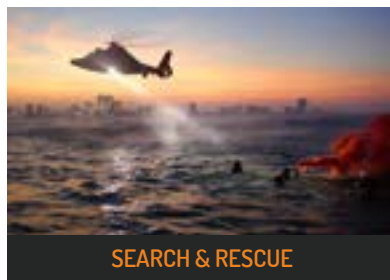

SEARCH & RESCUE

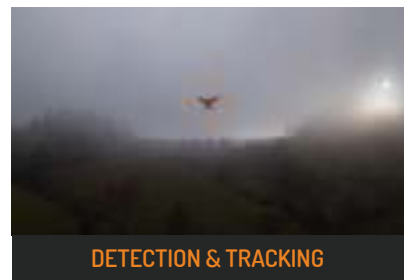

DETECTION & TRACKING



THREAT IDENTIFICATION



INFORMATION PROJECTION

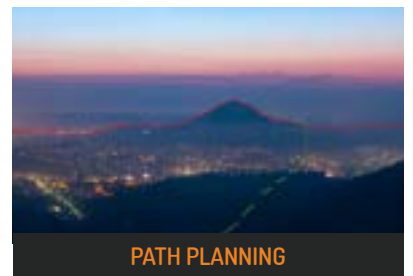

PATH PLANNING



MAPPING

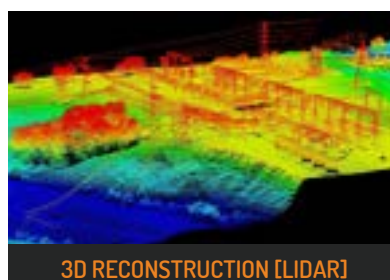

3D RECONSTRUCTION [LIDAR]

MIL-STD
810 - 1275B

RTCA
DO-160

COMPATIBLE WITH ALL NEXVISION' SENSORS & ALL DEVICES OF THE MARKET :

Video camera in Visible, Infrared night vision (VNIR, SWIR, thermal MWIR/LWIR) or Active 3D LiDaR/RaDaR

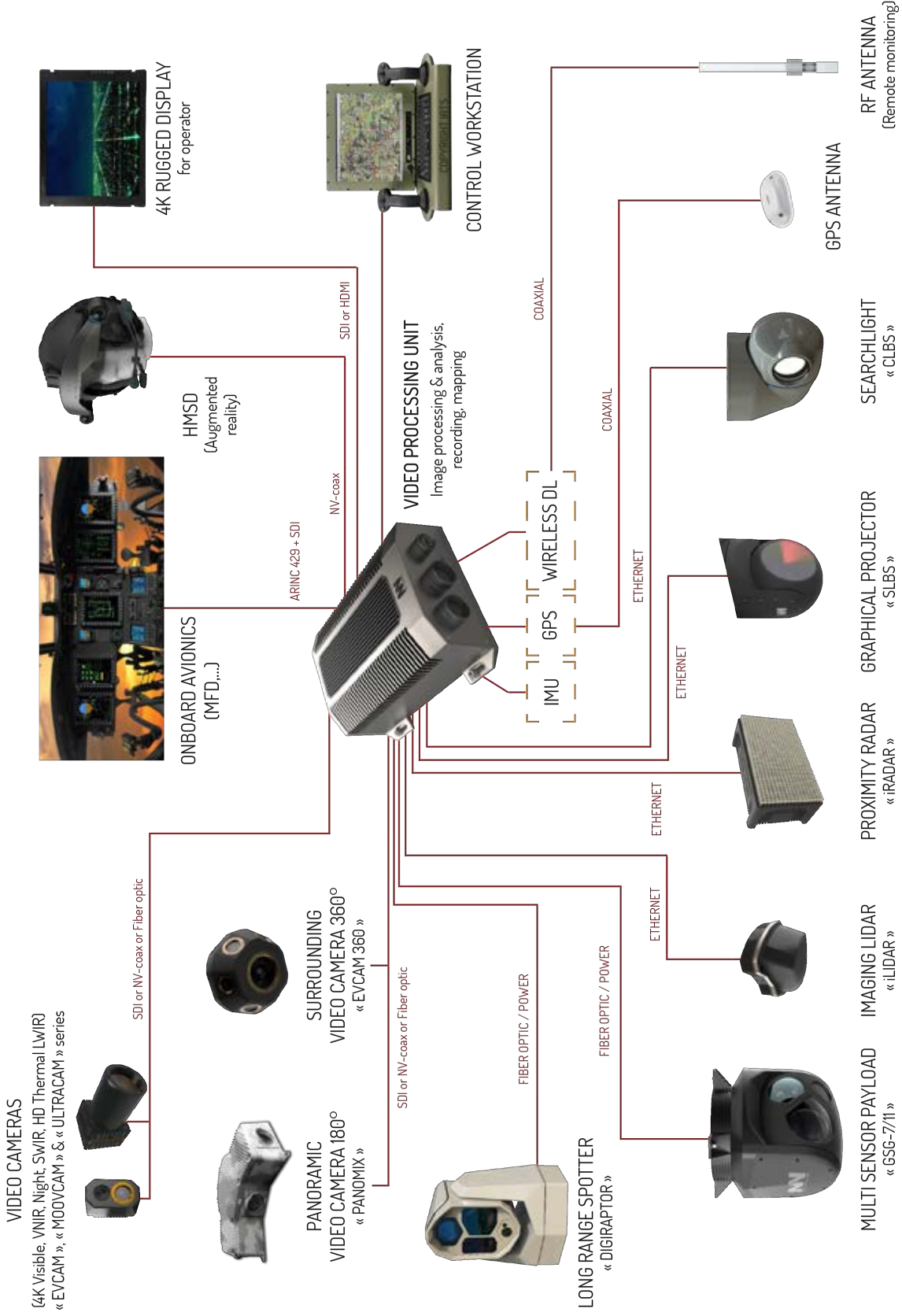



I/O

VIDEO INPUTS

12x Digital (mix of the following type of links)

- **Optical fiber** (proprietary fiber optic protocol)
>16 Gb/s per lane [0 ; 70] °C
>10.3 Gb/s per lane [-40 ; +85] °C
- **SDI** 12G/6G/3G
- **NV-COAX** up to 16 Gbit/s Down Link + camera control Up Link + 20w power-over-coax

VIDEO OUTPUTS

Digital

- **12x SDI** 12G/6G/3G
- **1x HDMI** 4096x2160 at 60 Hz

Analog

- **2x Composite PAL/NTSC** (CVBS)
- **Optional : 2x STANAG 3350** Class B

DATA LINK

USB

- **USB 3.1** type C connector

Ethernet

- **2x Ethernet Gigabit** Slot M12 (1000 BASE-T)
- 1x Ethernet Gigabit **switch**

Serial

- **4x RS485/422**
- **Optional : ARINC 429** 8x IN / 6x OUT (100 kb/s)

STORAGE

SSD

- **2x SSD NVMe** up to 10 TB

EEPROM

- 1x 2Mb EEPROM per SoC
- 1x 2Mb EEPROM for FPGA

OTHERS

Discrete I/O

- 4x protected I/O 28V

Temperature management

- Airflow cooling

ENVIRONMENT

MIL-STD 810G compliant

- Operating temperature Range : -20°C to 70°C
- Humidity : 10-90% non condensing

VIDEO PROCESSING PERFORMANCE

Front-End Image Co-processor (FPGA)

- 650k logic elements
- 22 Mb SRAM
- 3x 1GB DDR4 @2666 Mb/s (42.66Gb/s)
- 512 Mb NOR Data Flash

System on Chip GPU modules

Up to 3x onboard parallel NVIDIA® Jetson AGX Xavier™ Module.

Each SoC has the following performance :

CPU	CPU 8-core Carmel ARM v8.2 64-bit CPU, 8MB L2 + 4MB L3
GPU	GPU 512-core Volta GPU with 64 Tensor Cores 11 TFLOPS (FP16) 22 TOPS (INT8)
AI performance	32 TOPs DL Accelerator (2x) NVDLA Engines* 5 TFLOPS (FP16), 10 TOPS (INT8)
Vision accelerator	7-way VLIW Vision Processor
Video capabilities	Video Encode 2x1000MP/sec 4x 4K @ 60 (HEVC) / 8x 4K @ 30 (HEVC) 16x 1080p @ 60 (HEVC) / 32x 1080p @ 30 (HEVC) Video Decode 2x1500MP/sec 2x 8K @ 30 (HEVC) / 6x 4K @ 60 (HEVC) 12x 4K @ 30 (HEVC) / 26x 1080p @ 60 (HEVC) 52x 1080p @ 30 (HEVC) / 30x 1080p @ 30 (H.264)
Embedded memory	32GB 256-Bit LPDDR4x 136.5GB/s
Embedded storage	32GB eMMC 5.1
FPGA link	PCIe Gen 3 1x SoC with 8 lanes and 2x SoC with 4 lanes

PARTNERS



IMAGE PROCESSING : NEXIP™

FPGA (Image Pre-Processing)

- Video enhancement and advanced video processing : Temporal noise filtering and contrast enhancement
- Multiple exposure blending provides realtime HDR for high details retention in low and over exposed area
- Multispectral band image sensor fusion (Visible, SWIR, Thermal IR)
- Feature point extraction, image stabilization, denoising

GPU (Image analysis and codec)

- Object detection, recognition, tracking
- Machine learning / AI / Pattern matching
- 3D perception / SLAM / 360° vision (stitching)
- Full framerate, 4K high quality video encoding

SOFTWARE DEVELOPMENT

Dedicated Embedded Linux BSP based on Buildroot, including:

- U-boot bootloader
- Custom Linux kernel based on NVIDIA sources
- Integration of NVidia Tegra specific frameworks: CUDA®, OpenCV, OpenGL TensorRT™, cuDNN, NVIDIA DIGITS™ Workflow, NVIDIA VisionWorks™, Camera Imaging, Video CODEC.
- Customizable failsafe update system (FPGA, Software)
- Embedded debugging and profiling tools: quadd, nvprof, cuda-gdb, gdb, LTTng

External debugging and profiling tools:

- Tegra system profiler, NVIDIA NSight

Specific drivers:

- FPGA: PCIe based, video acquisition, video display, Xilinx IPs (UART, SPI, I2C, XADC, ...), High Speed Inter SoCs communication channel, generic data transfer to/from SoC modules
- Arinc 429: network socket interface based, label filtering, high/low speed configuration, multi-channel support

Nexvision's Middleware:

- Video Analysis Framework
- Embedded Video Recording: H264, H265, MP4, MKV, AAC
- Video streaming: RTSP/RTCP/RTP, H264, H265, AAC

POWER SUPPLY

MIL-STD 1275B compliant

Voltage range	9-36 V _{DC}
Power consumption	
• Light process > 1 SoC (40% Load) > Ambient temp : 25°C	35W
• Typical application > 2 SoC (70% Load) > Ambient temp : 55°C	75W
• Peak process > 3 SoC (100% Load) > Ambient temp : 70°C	120W

LOW SWaP-C

Size : 300x220x109 mm
weight : 5.5kg

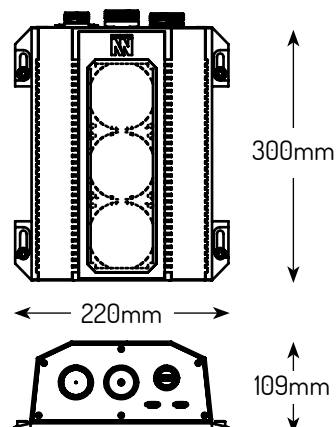



PORTABLE VIEWER



WE DESIGNED DIGITOWL, A PORTABLE DIGITAL SIGHT IMAGER THOUGHT ESPECIALLY FOR SPECIAL FORCES, THAT MATCHES LOW SIZE, WEIGHT, POWER AND COST (SWAP-C) CHARACTERISTICS. IN ADDITION, DIGITOWL IS ABLE TO EMBED VERY LOW LIGHT SENSOR (DOWN TO NATO LEVEL 5 WITH EBCMOS SENSOR FROM PHOTONIS).

DIGITOWL

PORTABLE HD DARK NIGHT SIGHT IMAGER

NATO NIGHT LEVEL : 4 or 5

FEATURES

- Overcast starlight digital night vision (down to NATO level 5, down to 100 μ Lux)
- Very high resolution : 7Mpixels, 4Mpixels (2K x 2K) or 2Mpixels (2K x 1K)
- Digital zoom x2, x4, x8
- Night Detection, Recognition, Identification
- Single-hand operation
- HD Microoled display
- Autogated
- Autonomy : 8 hours
- Digital video output : HD-SDI (SMPTE 292)



SYSTEM CAPABILITY

- Adjustable display brightness
- Proximity sensor (display turns off when device is removed from the eyes)
- Digital zoom
- «Eventcheck» function to review last 30 seconds as video or image by image
- Positioning : geographic horizontal position (GPS latitude and longitude, date and time) and 3D orientation
- Menu to access system functions and settings
- Outgoing interface for wireless transfer of video

DRI VALUES

Detection*	Vehicle	1 900m (9px)
	Human	1 320m (9px)
Recognition*	Vehicle	480m (34px)
	Human	330m (34px)
Identification*	Vehicle	375m (45px)
	Human	260m (45px)

**About DRI : Applying Johnson criteria to a high resolution sensor is not relevant. Since our sensor has 4 times the resolution, we define the DRI thresholds as indicated in the diagram. Calculating DigitOWL DRI values for a human according to Johnson criteria would result in D=5.2km (2.25pixels), R=1.3km (4.8pixels), I=1km (6.4pixels).*



APPLICATIONS

- Defense
 - Special Forces
 - Land / Naval / Air
- Customs
- Civil security



PRODUCT NAME	SPECIAL FEATURES
DigitOwl-EB4M « Essential »	EBCMOS intensified sensor from PHOTONIS Resolution : 4M pixel Spectral band : near infrared Night level sensitivity (NATO) : 5 Export regulation restriction
DigitOwl-EB2M « Essential »	EBCMOS intensified sensor from PHOTONIS Resolution : 2M pixel Spectral band : near infrared Night level sensitivity (NATO) : 5 Export regulation restriction
DigitOwl-IC7M « Essential »	iCMOS intensified sensor from PHOTONIS Resolution : 7M pixel Spectral band : near infrared Night level sensitivity (NATO) : 4 DUAL USE (but export regulation : FOM > 1600)
DigitOwl-IC7M « Essential »	ITAR FREE iCMOS intensified sensor from PHOTONIS Resolution : 7M pixel Spectral band : near infrared Night level sensitivity (NATO) : 4 DUAL USE (Export regulation relaxed for FOM < 1600)
DigitOwl-VIS7M « Essential »	Color CMOS sensor from SONY Resolution : 7M pixel Spectral band : visible High dynamic range Night level sensitivity (NATO) : 2.5

OPTIONS

« Extended »	GPS, Compass-IMU, distance evaluation reticule
« LRF »	Laser range finder (3km range)
« LWIR320 »	Thermal Infrared LWIR - Sensor: ULIS's ATT0320 - Fixed focal length

ACCESSORIES

Battery power pack	10 Ah
Front protection optical filter	UV and NIR filter - scratch and water proof



PANORAMIC CAMERA



NEXVISION DESIGNED PANOMIX, A RUGGED PERIMETRIC SURVEILLANCE SYSTEM BASED ON A COMBINATION OF MULTIPLE 12MP COLOR SENSOR. ALSO AVAILABLE FOR NIGHT VISION WITH EBCMOS SENSOR.

PANOMIX

ACCURATE SITUATIONAL AWARENESS

RUGGED PERIMETRIC SURVEILLANCE SYSTEM

FEATURES

- 120° / 180° / 360° panoramic vision with realtime video stitching
- Customizable solution depending on vehicle constraints
- High performance video camera **up to 72MP** global shutter high sensitivity sensors
- Available with Photonis EBCMOS sensor (night vision : down to level 5), up to 24MP
- Realtime intrusion detection and track following
- Fiber optic for long reach (up to 100m) uncompressed video transmission or wireless digital link for realtime H264 video streaming for drones
- Embedded inertial measurement unit for accurate video stabilization and worldspace measurement

ABOUT PANOMIX

Panomix is a perimetric surveillance system based on a combination of multiple 12MP global shutter color sensor with very high sensitivity (down to NATO Night Level 2), a realtime panorama stitching system and a operating software for controlling, recording and playing back. Panomix is also available with EBCMOS sensor for night vision (down to NATO Level 5).

Panomix is available in numerous configuration customizable to fit the carrier, from two 180° modules, three 120° modules, or six 60° modules. Each module processes its own 9 axis inertial measurement unit.

It's weatherproof and waterproof (IP67) with "marine condition".

The marine casing is made to avoid reflecting radar echo wave (fit stealth mode requirement)

APPLICATIONS

- Surveillance
- Situational awareness
- Defense
- Aerospace

PARTNERS

PHOTONIS

SONY

XILINX

samtec



PCI EXPRESS



Exemple panoramic vision 120°



**4K
ULTRA HD**

NEXVISION



**Fiber
OPTIC**



60°

60° / 120° / 180° / 360°

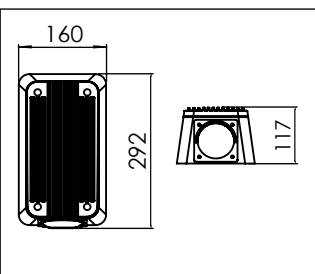

Weight : 5.5kg

120°

120° / 360° (3x120°)

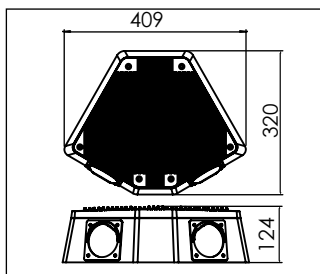

Weight : 9.5kg

180°

180° / 360° (2x180°)

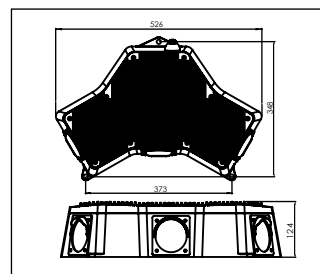

Weight : 13.5kg

OPTIONS

Map	Geographical Information System (GIS) vectorized mapping on the Command Control software (C4-ISR)
Sea ranging	Over the sea distance evaluation Passive/image processing based (no active imaging/ToF)



PANORAMIC CAMERA PANOMIX



HEAD MOUNT DISPLAY



AUGMENTED REALITY AND FUSION, COMBINED WITH
NIGHT VISION SENSORS AND IMAGE ANALYSIS.

EXTREM OWL

COLOR NIGHT VISION SYSTEM FOR HELICOPTER PILOT HELMET WITH AUGMENTED REALITY

FEATURES

- KAMELEON sCMOS color night vision sensor
- Image projection on the visor thanks to micro-oled displays
- Stand alone helmet mounted display
- High resolution
- Wide field of view
- Clear picture of obstacles
- Good contrast
- Comfort of sight
- Compatibility with onboard avionics systems
- Security in flight conditions
- High dynamics

PHOTONIS KAMELEON SENSOR

- Color
- sCMOS
- 1.3 Mpx



**“A TREMENDOUS
COLOR VISION
IN LOW LIGHT
CONDITIONS!”**



NAKED EYE



NVG



WITH EXTREM OWL



NVS-11

NIGHT VISION SYSTEM FOR SPECIAL FORCES

AUGMENTED REALITY ON THE VISOR

(data & multi image sensor fusion display)

FEATURES

- Image projection on the visor thanks to micro-oled displays
- EBCMOS night vision sensor (NATO level 5)
- MWIR/Thermal sensor
- Augmented reality on the visor (data & multi image sensor fusion display)
- Mission-based symbology
- Human body detection, pattern matching, friends localization (to avoid blue on blue)
- Field of view > 80°
- Embedded image processing & analysis (Nvidia Tegra family GPU)
- Separate sensor & display => Removable tactical optronic (IR cam, wireless spy cam)
- Simultaneous Day/Night mode with the same sensor without interruption
- High resolution
- Best depth restitution Interoperability with C4-ISTAR
- System lighter than other existing systems :
 - Less than 700g on the helmet
 - Less than 1.5kg on the soldier, including batteries & processing unit
 - Standard helmet mount

EBCMOS SENSOR

- Definition: 1.3Mpixel or 4Mpixel
- Black and white
- Sensitivity: 100µLux
- Automatic day night commutation
- Sensor cooling

WHAT YOU SEE INSIDE THE VISOR



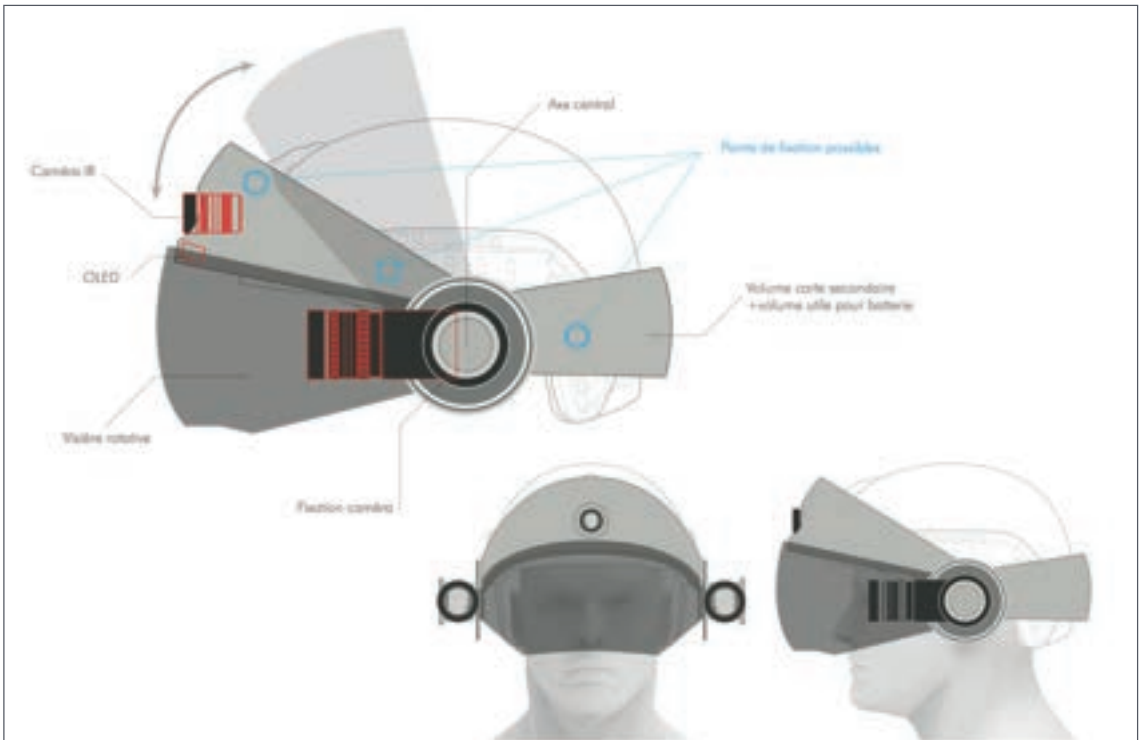
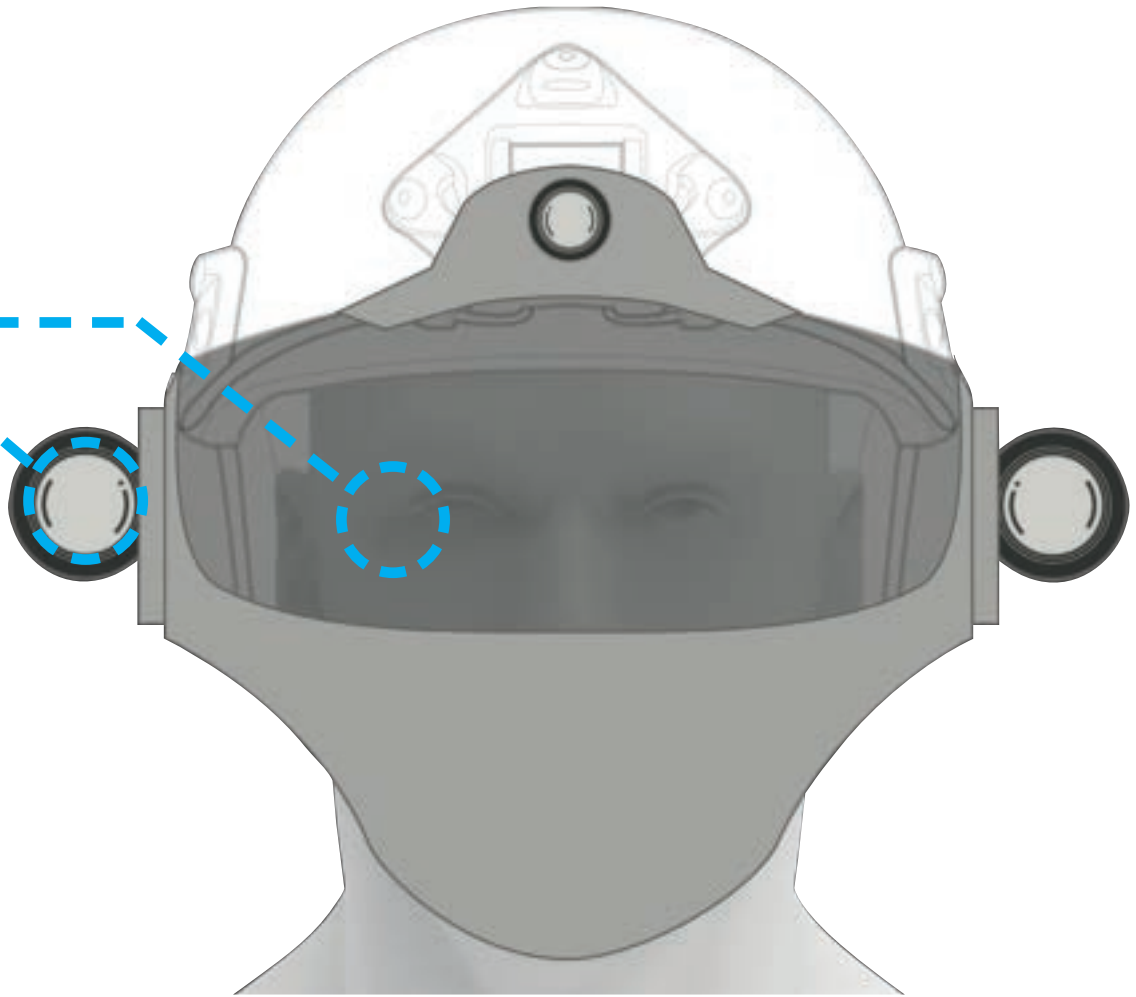

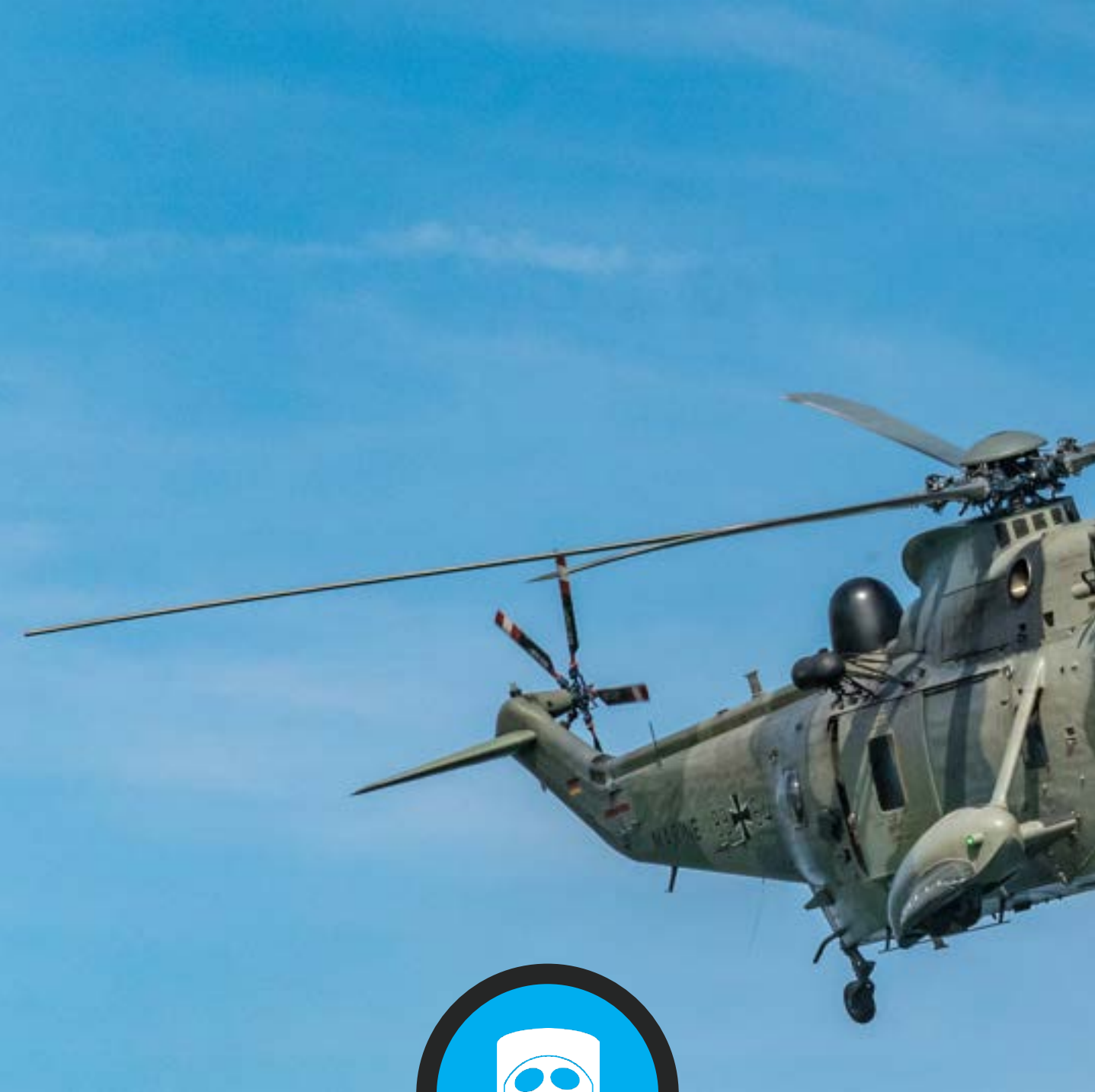

GYRO POD



A RANGE OF GYROSTABILIZED GIMBALS FOR MANNED OR
UNMANNED PLATFORM.

GSG-9 / GSG-11

LONG RANGE GYROSTABILIZED GIMBAL

THE MOST POWERFUL POD OF THE MARKET !

FEATURES

For all manned or unmanned airborne platforms [UAV, Helicopter..]

- Ultra HD 4K color & HD night vision [starlight night level 4/5]
- Dual spectral band long range zoom lens (40° to 2°) : VIS & VNIR, 4K Ultra HD
- Huge image processing computing power (AI/deep learning processor)
- Ergonomic slaving to a high power laser searchlight
- Full 3D situational awareness, tracker
- Multispectral image sensor fusion
- IP video & meta data streaming
- Embedded image analysis [target tracking, human body detection, vehicle pattern detection]
- Fast & accurate dual axis motorization (direct drive)
- Quick deployment & maintenance
- Low price, interoperability and flexibility of the solution, low logistic footprint

Optional :

- SWIR, Thermal LWIR, MWIR with multispectral image sensor fusion
- Through fog active vision (range gated)
- Laser searchlight

APPLICATIONS

- Surveillance (situational awareness)
- Research & tracking
- Fire fighting
- Crisis management
- Protection of sensitives sites and events
- Law enforcement



MORE

Human machine interface control

[by Extrem OWL : optical see through helmet mounted sight and display]





PAYLOAD SPECIFICATIONS

SENSOR #1 : COLOR VISIBLE

- 7 Mpixel SONY-IMX420
- Resolution : 3208 x 2200
- Pixel : 4.5µm
- Continuous optical zoom
- Fields of view : 2° to 40°
- Magnification : x20

SENSOR #2b : SWIR

- Resolution : 640 x 512
- Fields of view : 2° to 40°
- Magnification : x20

SENSOR #3b : THERMAL LWIR 8-13µm

- Resolution : 640 x 480
- Pixel : 12µm
- Fixed focal lens : 4°

SENSOR #2a : NIGHT VISION

- 4 Mpixel EBCMOS PHOTONIS
- Visible & near Infrared
- Continuous optical zoom
- Fields of view : 2° to 40°
- Magnification : x20
- Sensitivity : 100µlux

SENSOR #3a : THERMAL MWIR 3-5µm

- MCT
- Resolution : 1280 x 1024
- Cooling by Stirling engine
- Continuous optical zoom
- Fields of view : 4° to 40°
- Magnification : x10

**Combination of : 1 + (2a or 2b) + (3a or 3b)*

GSG-9

- 11.7 kg / 25.8 lbs
- 228mm (D) x 310 mm (H)
- 9"(D) x 12.2"(H)

GSG-11

- 18.2 kg / 40.1 lbs
- 278mm (D) x 310 mm (H)
- 11"(D) x 12.2"(H)

DIGIRAPTOR

LONG RANGE SPOTTER WITH GYROSTABILIZED GIMBAL

“

A small, multispectral, ultra-high resolution, electro-optic long range gyro-stabilized targeting viewer (spotter). With unique features like 4K dark night vision intensifier, 4K color night vision, HD thermal sensor, integrated search light, extremely powerfull deep-learning image analysis processor and user friendly interfaces.

APPLICATIONS

- Surveillance (situational awareness)
- Border & Maritime Patrol / Protection
- Tactical Surveillance & Armed Reconnaissance
- Target designator, spotter
- Research, tracking and rescue (SAR & CSAR)
- Public Safety (Fire fighting and Rescue)
- Crisis management /Disaster Response
- Protection of sensitives sites and events
- Law enforcement

detection

tracking

night
vision

4K

MWIR

LRF

FEATURES

SENSORS

- Dual spectral band ultra-high resolution night vision :
 - > 4K x 2K (8Mpixel) color, night level 2
 - > 2K x 1K (2Mpixel) VNIR, night level 3
 - > Long range zoom lens (40° to 2°) : VIS & VNIR
- Thermal MWIR vision, long range continuous zoom with optical stabilization, resolution VGA 0.3Mpixel.

VIDEO PROCESSING

- Huge video and data computing power (AI / neural network processor)
- Embedded image analysis (target tracking, human body detection, vehicle pattern detection)
- Full 3D situational awareness, tracker
- Multispectral image fusion

MOTORIZATION

- Fast & accurate dual axis motorization (direct drive)

HIGHLIGHTING

- Laser Range Finder (LRF, SWIR band eyesafe)
- Laser pointer and illuminator (near IR)

COMMUNICATION

- IP video & meta data streaming
- Wireless video and data downlink (WIFI)

OPERATIONAL

- Quick deployment & maintenance
- Low price, interoperability and flexibility of the solution
- Low logistic footprint





OPTIONAL FEATURES

SENSORS

Second spectral band :

- Night vision : 2K x 2K (4Mpx) intensified, starlight night level 5 (icmos)
- or ▪ Through fog active range gated imaging (SWIR eyesafe)
- or ▪ High frame rate SWIR sensor, VGA resolution
- SWIR or Visible band spotter, ultra narrow angle fixed focal lens (0.5°)
- Thermal LWIR band spotter, narrow angle fixed focal lens
- Thermal MWIR, HD 1.3Mpixel, long range zoom with optical stabilization

HIGHLIGHTING

- High power laser beam illuminator/searchlight

TARGET DESIGNATOR

- Target designator (PGM, STANAG 3733)

COMMUNICATION

- Long range wireless video and data downlink (150kms)
- Automatic slaving to a radar



PANOSPOT

ACCURATE SITUATIONAL AWARENESS

RUGGED PERIMETRIC & LONG RANGE ZOOM SURVEILLANCE SYSTEM

- 360° panoramic vision with realtime video stitching
- Panoramic view : darknight vision with 24Mpixel EBCMOS sensor + day vision with up to 72MP high sensitivity global shutter color sensor
- Pan tilt zoom narrow view : day color with 4K 8Mpixel sensor + through fog night vision with 4K 8Mpixel EBCMOS SWIR sensor
- Realtime intrusion detection and track following
- Fiber optic for long reach (up to 100m) uncompressed video transmission or wireless digital link for realtime H265 video streaming for drones
- Embedded inertial measurement unit for accurate video stabilization and world-space measurement

CHARACTERISTICS

TECHNICAL INFORMATION

- A single fiber optic cable carries from one to three camera uncompressed video up to 100m distance. Fiber optics brings EMI and ground potential fluctuations immunity. The processing system fits in a 4U chassis.
- Power consumption for the camera is less than 40W
- 500W for the processing system

PROCESSING UNIT

- Depending on the needs of your application : could be a PC or an embedded solution based on FPGA and GPU.

COMMUNICATION

- Single 24-fiber optic cable with MTP connector per camera block (1 to 3 cameras per block)
- Up to 100m reach
- Hardened for harsh environments (Carlisle LITEflight HD cable)
- EMI and ground potential difference immune

CAMERA HEAD UNIT POWER

- DC 10-28V
- Up to 15W per camera

APPLICATIONS

- Situational awareness
- Yacht / vessel protection
- Border / arbor surveillance
- Vision based detection, point & tracking



4K
ULTRA HD

Fiber
OPTIC



ABOUT PANOSPOT

Panospot is a perimetric surveillance system based on a combination of multiple 12MP global shutter color sensor with very high sensitivity (down to NATO Night Level 2) combined with multiple 4MP EBCMOS night vision sensor (NATO Night Level 5), a realtime panorama stitching system, a video analysis with a huge processing power to detect threads around and then spot-on with a Pan-Tilt-Zoom gyrostabilized pod, and a operating software for controlling, recording and playing back.

Panospot is available in numerous configurations customizable to fit the carrier. It's weatherproof and waterproof (IP67) with "marine condition".

PARTNERS

PHOTONIS

SONY

XILINX

PCI EXPRESS





MOOV CAM



MOOVCAM IS A MODULAR VIDEO CAMERA WHICH HAS BEEN DESIGNED FOR MANY APPLICATIONS. IT ALLOWS TO CUSTOMIZE YOUR SIGHT VIEWER ACCORDING TO YOUR NEEDS (sensor, housing, I/O...)

MOOVCAM

HIGH PERFORMANCE VIDEO CAMERA

A MODULAR CAM FOR MANY APPLICATIONS



SENSORS

- Visible (2M / 3M / 7M / 9M / 12M / 50M / 100M)
- VNIR / Night (2M / 4M)
- SWIR / EBSWIR
- Thermal : MWIR (1.3M), LWIR (0.1M / 0.3M / 1.3M)

OPTICS

- Fixed focal
or
 - Motorized zoom x20
- Optic mount options
- C/CS
 - Micro 4/3
 - Canon EF-S

Mounting kit

Possibility to couple multiple Moovcam to enlarge the field of vision : 60° / 120° / 180° / 360°
Stitching is done with our in-house algorithms.



HOUSING

- Industrial
- Marine
- Waterproof

Video Link
Instant display
(without storage)



- SDI
- Full HD
- 5 to 8 inches

VIDEO / DATA LINK

I/O #1

- Fiber optic (PCIe or direct)
- SDI (3G / 6G)
- CoaXPress (CxP3 / CxP6)

I/O #2

USB
or
Camera Link

PC

Frame Grabber
Board PCIe_switch
2, 4 or 8 lanes with
Fiber optic



CUSTOM EMBEDDED SYSTEM

Embedded Frame
Grabber

(CamMaster 3D)
Embedded VPU

Media SoC
Nvidia / AMD

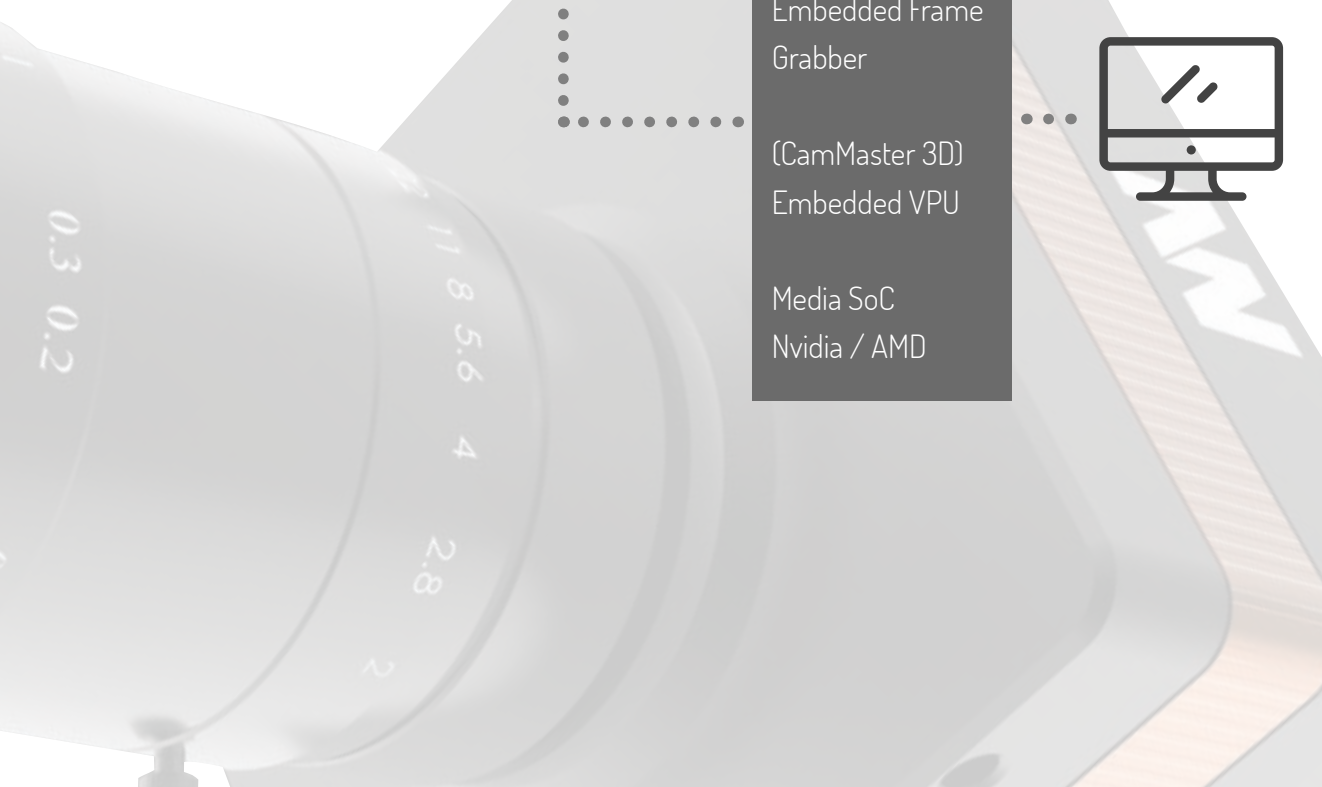
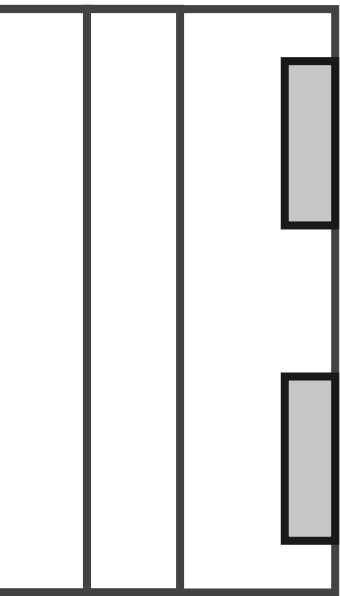

MOOVCAM

HIGH PERFORMANCE VIDEO CAMERA

VERSIONS

PRODUCT NAME	SPECIAL FEATURES
VNIR Night vision : Photonis's EBCMOS/iCMOS	
MOOVCAM « EBCMOS 4M »	Spectral band : near infrared Sensor : PHOTONIS EBCMOS intensified Resolution : 4M pixel Night level sensitivity (NATO) : 5 Export regulation restriction
MOOVCAM « EBCMOS 2M »	Spectral band : near infrared Sensor : PHOTONIS EBCMOS intensified Resolution : 2M pixel Night level sensitivity (NATO) : 5 Export regulation restriction
MOOVCAM « iCMOS 12M »	Spectral band : near infrared Sensor : PHOTONIS iCMOS intensified Resolution : 12M pixel Night level sensitivity (NATO) : 4 Export regulation relaxed with FOM < 1600
MOOVCAM « iCMOS 7M »	Spectral band : near infrared Sensor : PHOTONIS iCMOS intensified Resolution : 7M pixel Night level sensitivity (NATO) : 4 Export regulation relaxed with FOM < 1600
MOOVCAM « iCMOS 3M »	Spectral band : near infrared Sensor : PHOTONIS iCMOS intensified Resolution : 3M pixel Night level sensitivity (NATO) : 4 Export regulation relaxed with FOM < 1600
LWIR : ULIS's uncooled bolometer	
MOOVCAM « LWIR 320 »	Spectral band : Thermal Infrared LWIR Sensor : LYNRED-ULIS's ATTO320 Resolution : 320 x 240
MOOVCAM « LWIR 640 »	Spectral band : Thermal Infrared LWIR Sensor : LYNRED-ULIS's ATTO640 Resolution : 640 x 480
MOOVCAM « LWIR 1280 »	Spectral band : Thermal Infrared LWIR Sensor : LYNRED-ULIS's ATTO1280 Resolution : 1280 x 1024





PRODUCT NAME	SPECIAL FEATURES
SWIR : SOFRADIR's uncooled	
MOOVICAM « SWIR 640 »	Spectral band : Short Wave IR SWIR Sensor : LYNRED «SNAKE» Resolution : 640 x 512 Dual Use - export regulation free
VISIBLE	
MOOVICAM « VIS7M420 »	Spectral band : Visible, Color Sensor : SONY's «Pregius» global shutter IMX420 Resolution : 7M pixel High dynamic range Night level sensitivity (NATO) : 2.5
MOOVICAM « VIS12M253 »	Spectral band : Visible, Color Sensor : SONY's «Pregius» global shutter IMX253, 1.1inch Resolution : 12M pixel Night level sensitivity (NATO) : 2
MOOVICAM « VIS12M226 »	Spectral band : Visible, Color Sensor : SONY's «Starvis» IMX226, 1/1.7inch Resolution : 12M pixel
MOOVICAM « VIS4M »	Spectral band : Visible, Color Sensor : CMOSIS's CMV4000, 1inch Resolution : 4M pixel, 2000x2000
Interface choice	
PCIe over fiber optic link , 3G/6G-SDI output, USB link (type C connector), CameraLink	
Frame grabber choice	
Frame grabber PCIe (2, 4 or 8 channels fiber optics), USB link (4 channels), CameraLink	
Lens mount choice	
Micro 4/3 mount with motorized lens control link, CS type lens mount (C to CS adaptor)	

MOOVCAM « VIS12M253 »

HIGH DEFINITION AND ULTRA FAST VIDEO CAMERA

IDEAL FOR FAST MOVING OBJECT

FEATURES

- High performance video camera (12Mpx - 4K 60fps - 4096 x 3000px)
- **Fiber Optic** : long reach (up to 100m at full 16Gb/s speed), EMI immune, low cost OM3 MTP fiber optic cable
- Thanks to USB-C & PCIe, MOOVCAM uses the full performance of the **SONY IMX253** sensor
- No image distortion thanks to global shutter (even when observing fast moving objects)
- Optimized vision chain : combined with our NV_PCl_e_Switch board, the vision chain is much simpler (fewer interfaces, lower latency)
- Open IP
- Reduced housing

APPLICATIONS

- Machine vision (industrial)
- Traffic monitoring
- Broadcast / Cinema
- Surveillance
- Life science / Medical
- Microscopy



SONY-IMX253 SENSOR

- Global shutter
- Max **12.37Mp** 4/3 (4096 x 3000)
- 68fps (8 bit) / 64fps (10 bit) / 46fps (12 bit)
- 17.6mm diagonal (Type 1.1")
- 3.45µm square pixels



PARTNERS

SONY

samtec

XILINX



PCI EXPRESS

Type C

USB

4K
ULTRA HD

FIBER
OPTIC



Pregius
Global Shutter Technology

B&W or COLOR



USB3.0 / Fiber Optic
version

Camera Link + SDI / CXP
version

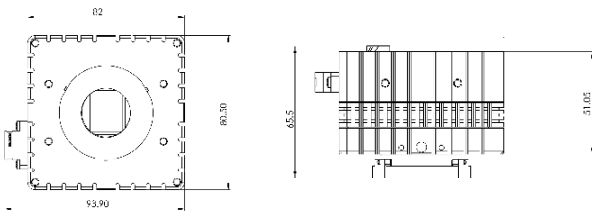

Weight : 380g w/o lens

OPTIONS

Video link : CameraLink, SDI, CXP6

Lens : Panasonic Micro 4/3 with electronic lens control, Canon EF-S series

Sensors : SONY Pregius gen 2&3 serie + IMX226, CMOSIS CMV & CSG, ONSEMI Cypress PYTHON, ONSEMI-Aptina AR, SOFRADIR SWIR SNAKE & LWIR ATTO, ...





SPOT
LIGHT



A RANGE OF SPOTLIGHTS FOR DIFFERENT MISSIONS :
TAKE OFF, LANDING, SEARCH & RESCUE AT NIGHT.

SLBS

SCANNING LASER BEAM SEARCHLIGHT

KEY FEATURES

- High power RGB laser light source (80 000 lumen light output)
- Beam shape of any pattern of any RGB color mix at any point
- Long range lighting up to 3km
- Low power consumption <450W, low size 150mm diameter, low weight 9.5kg
- Very low aerodynamic drag
- Dimmable light power
- Range finder option
- Easy to install. Maintenance free.
- Built-in tests (PBIT / CBIT)

BENEFITS

- Split light source and emitter head over fiber optic :
 - Laser light source can be ideally located close to electrical power source and cooling without being exposed to outdoors constraints
 - Projector head is compact, drastically reducing aerodynamic drag and associated consequences
- High power RGB laser light source :
 - Compact, high efficiency
 - High speed and wide range power modulation of individual colors
- Compact X-Y high speed scanning mirror head :
 - Combined with laser sources modulation enables to draw a wide variety of beam shapes and sizes and even project basic color graphics
 - Enables much wider beam size modulation than conventional searchlight without any optics

APPLICATIONS

- Aerial work
- Defense
- Search & Rescue
- Enforcement

SPECIFICATIONS

Beam-shape fan angle : 0.3° to 50°

Gimbal steering :

- > Azimuth : +210° to -210°
- > Elevation : +20° to -180°



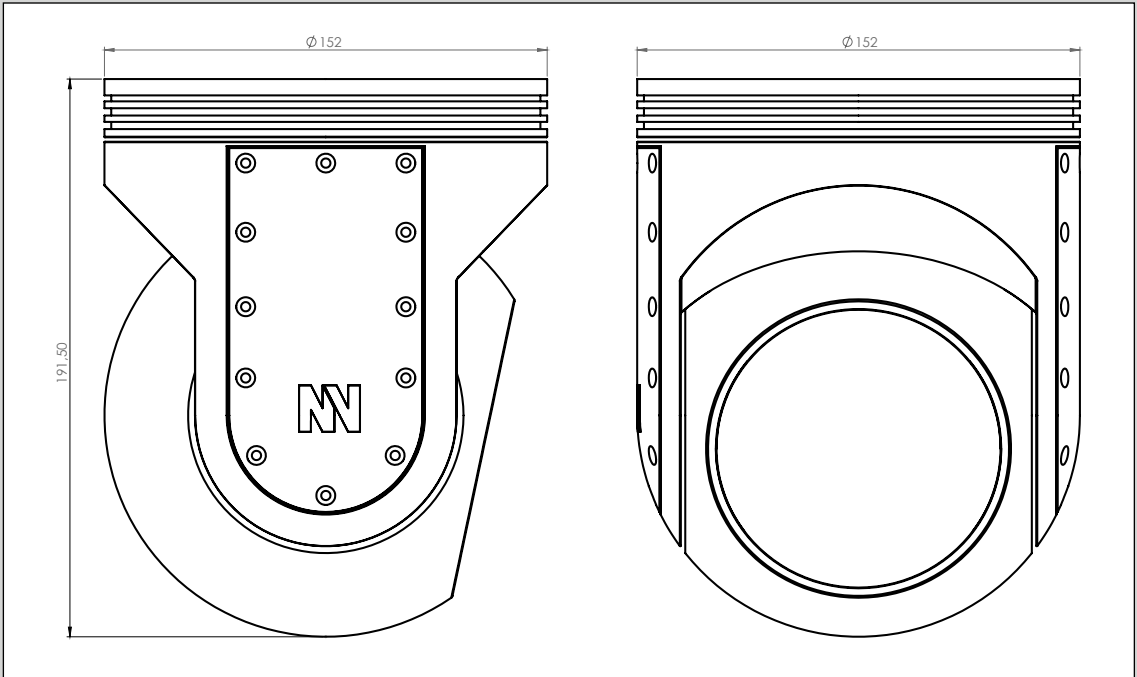

CLBS

COLOR LASER BEAM SEARCHLIGHT

TAKE OFF, LANDING, SEARCH & RESCUE AT NIGHT

KEY FEATURES

- Laser lighting
- Spectral band : R + G + B + optional near infrared (VNIR and/or SWIR)
- Power output up to 30 000 lumen dimmable
- Working distance range : range 0.1 (328ft) to 3km (~10kft) thanks to LASER's sustained beam coherency.
- Useful range for human target identification : typical 1km (~3.5kft)
- Variable beam divergence : 4° to 15°
- Night vision goggles compatible

BENEFITS

- Split light source and emitter head over fiber optic :
 - Laser light source located close to electrical power source and cooling without being exposed to outdoors constraints
 - Projector head is compact, drastically reducing aerodynamic drag and associated consequences
- High power RGB laser light source :
 - Compact, high efficiency
 - High speed and wide range power modulation of individual colors
 - Suspect's dizziness by strobing effect

SPECIFICATIONS

Searchlight head «SU» : gimbals subpart (outside aircraft)

- Envelope Size : Height 209mm (7.87") x Diameter: 195mm (7.68")
- Weight : 4.9kg (10.8lbs)
- Small ball design for a very low aerodynamic drag

Light beam generator & power supply subpart «PU» (inside aircraft)

- Main laser light generator
- Power supply to the searchlight head
- Size : Height 120mm (4.7") x Length: 300mm (11.8") x Width: 200mm (7.9")
- Weight : 3.9kg (8.6lbs)
- Heat dissipation : Active cooling with fan

User hand grip Remote Controller Unit «RCU» SUBPART (inside aircraft)

- Size : Height 30mm (1.2") x Length: 150mm (5.9") x Width: 120mm (4.7")
- Weight : 0.7kg (1.5lbs)
- Night Vision Goggles (NVG) compatibility (MIL-STD-3009)

Control panel (joystick, buttons, display)

- A second user controller: panel version with extended features and more informative display
- Master/slave priority switch
- NVG compliant



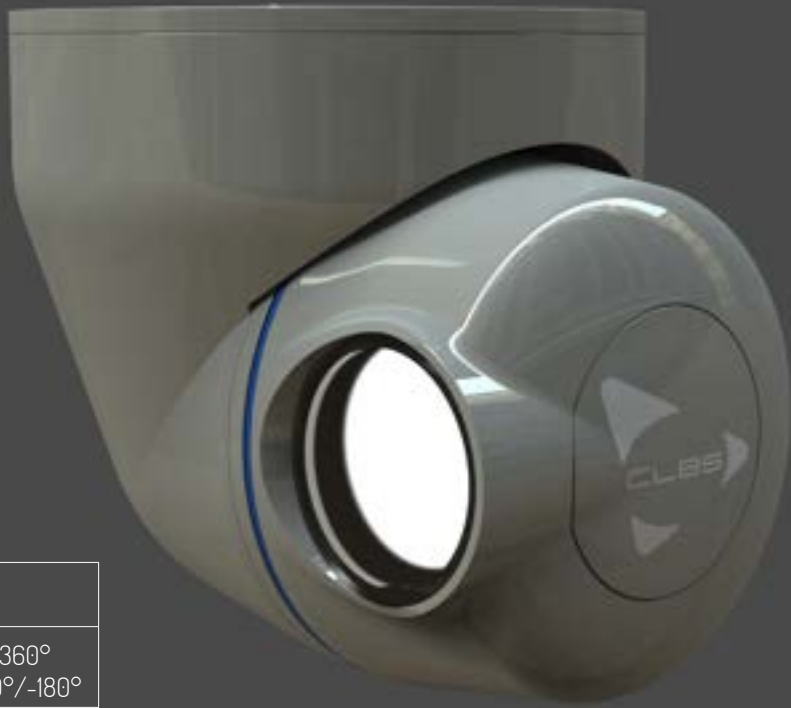

Speed rotation	180°/s
Rotation	Azimuth : n x 360° Elevation : +10°/-180°
Power consumption	1300W

INSTALLATION KIT

Mounted set : standard

- On fuselage head mounting enclosure
- Default mounting option : easy to mount, certified and maintain.
- Height 230mm (9") x Length: 210mm (8.27") x Width: 210mm (8.27").

Takeoff-landing approach lighting

- Take-off and landing light
- 10000lumen LEDs
- 60° fixed beam angle
- Available only on fuselage mounting set

Cables set : standard

- 1x PU <-> SU, 5m long (power supply «PU > SU» & high speed serial control link)
- 1 x PU <-> RCU, 10m long (power supply «PU > RCU» & control-command serial link)

Mounting custom set : brackets option

- Side mounted on A/C

SYNOPTIC

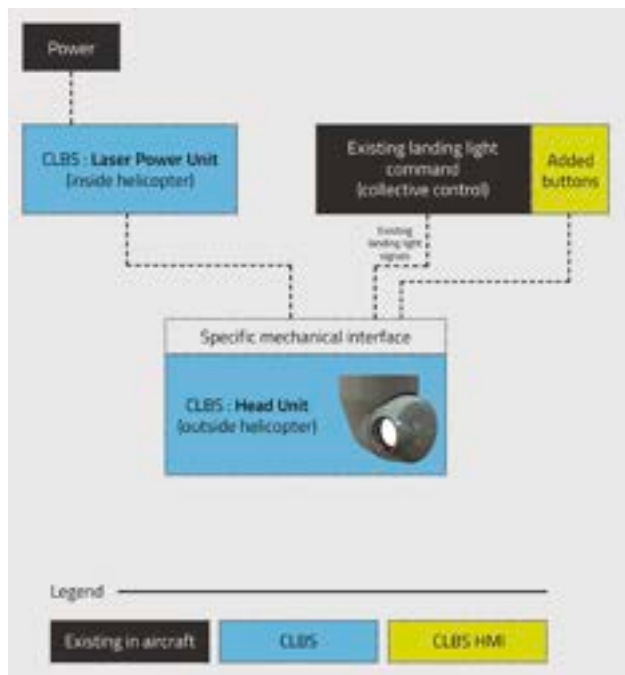

OPTIONS

- Slaving to electro-optics gyrostabilized gimbals (GSG9/11)
- Laser Near Infrared pointer (compatible with NVG devices)
- Laser Range Finder (eye safe SWIR, 1km range)
- LIDAR (high resolution 3D perception, «sense & avoid collision»)
- Thermal IR camera wide angle and narrow angle (LWIR)
- Color 4K camera, low light (quarter moon), continuous optical and digital zoom.

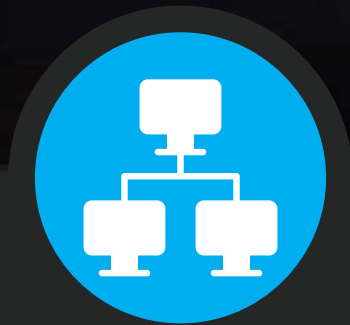

VMS C4-ISR



VMS IS OUR HOME-MADE VIDEO MANAGEMENT SYSTEM. MADE OF DIFFERENT TECHNICAL BRICKS, IT ALLOWS SEVERAL CONFIGURATIONS, DEPENDING ON THE GLOBAL SURVEILLANCE MONITORING CENTER.

NEXVMS

COMMAND & CONTROL CENTER (Safety & Security)

SURVEILLANCE MONITORING CENTER, COORDINATION OFFICE & VIDEO CAMERA SUPERVISION

FOR :

- Defense (C4-ISR)
- Government
- Border police
- Coast guards
- Companies

VERSIONS :

- City
- Airborne
- Marine vessel
- Cross-platform

PROTECTION OF :

- Cities (smart cities)
- Borders
- Maritime area
- Critical infrastructures
- Sensitive areas (SEVESO sites, banks, casinos, airports, military installation...)
- Onboard surveillance (aircrafts, vessels, train, tramway, bus...)

USE CASES



A380 CABIN VIDEO MANAGEMENT SYSTEM

- 30 cabin video camera
- Display adapter unit
- Crew monitoring display
- Remote monitoring display
- Ground monitoring display
- DVR (recorder)
- Display cockpit



FES CITY CCTV

- 300 HD video camera
- Wireless connection
- 25 monitoring screens
- Complete city map
- Redundancy for video storage
- Customized survey scenario
- Personal privacy protection
- 24/7

« Only 5 months after the beginning of deployment, the systems allowed 30 police interventions by day, increasing the security of all the town, for both citizens and tourists. »

NexCAM Smart™

1 to 20 Mpixel Network Video Camera

- Visible HD with and without HDR
- Night vision
- SWIR
- LWIR / Thermal
- Terahertz



NexRMC™

Remote Media Control Software

- High quality video & audio streaming
- Recording, digital I/O, PTZ control
- Ergonomic & intuitive interface
- Protocols & compatibility



NexNVR™

Network Video Server & Recorder

- Over IP Network
- Integrated automatism
- Low power RF link, Zigbee compliant
- Database security
- image watermarking on demand
- Data encryption on demand



CLASSPATH

Software Modular Architecture

- RTSP/HTTP/SFTP Client & Server
- Compression
- Ternary search tree
- File storage
- File format
- Cryptographic primitives
- Database
- Encoding
- Network
- Streaming
- Licensing
- Multi threading

NexMAP™

Human Interface Monitoring on geotagged GIS map

- Manages specific types of geographically referenced data with object management.



NexIO™

Automation, Access control & audio on IP network

- Autonomous audio/video security network controller
- IP PLC
- Connected home
- Urban automation



NexSETUP™

Allows configuration of sources, recording-schedules, users and configuration of NVRs

- Video source setup
- Source-group setup
- Video recording setup
- NVR setup
- User setup
- NEXIO setup

NexIP™

Powerful image processing & analysis algorithms library

- Optical enhancement, deconvolution, stabilization, pre processing, HDR & noise filtering
- Detection, recognition, Tracking
- Machine learning
- Environment measurement
- Number plate recognition





OUR QUALITY MANAGEMENT SYSTEM

The purpose of the Nexvision Quality Management System (NV QMS) is to assure the business through excellent products which fully satisfy or exceed customer expectations and user requirements. Quality Management Principles are:

- Customer focus
- Leadership
- Involvement of people
- Process approach

In order to develop safe systems within short delay, adapted, agile methods are applied in management and development. The applied methods are scrum and Agile Systems Engineering (ASE). For quality processes, this means that:

- A major part of the continuous improvement is simplification wherever possible
- Any rule which does not fulfil its purpose will be modified immediately.

The NV QMS is based on the requirements of the international standards ISO 9001:2015 and EN 9100:2016. This system addresses the design, development and production of the company's products. Identifying, understanding, and managing interrelated processes as a system contribute to the organization's effectiveness and efficiency in achieving its objectives.

INFRASTRUCTURE

To meet quality objectives and product requirements Nexvision has determined the infrastructure needed. The infrastructure has been provided, and includes workspace, utilities, process equipment and supporting services. As new infrastructure requirements arise, they will be documented. Existing infrastructure is maintained to ensure product conformity.

EQUIPMENT MONITORING & MEASUREMENT

All measuring and test equipment used for verification of products is calibrated using calibration standards traceable to the national standard. Calibration records are maintained. The calibration status of measuring equipment is identified with calibration stickers. The equipment is well maintained and its placement and use are controlled.

DESIGN & DEVELOPMENT

Design activities are defined with their milestones and reviews that are required to ensure a good design every time. In addition, responsibilities and means for requirements traceability and design approval are assigned. This process defines also how design changes are controlled and approved. Depending on the project and on customer requirements, different standard documents are applied. Current experience includes for example:

- MIL-STD-785B, MIL-STD-810
- STANAG 4370
- ARP4754a
- RTCA DO 160 / Eurocae ED-14
- RTCA DO 178 / Eurocae ED-12
- RTCA DO 254 / Eurocae ED-80

The development cycle will always be adapted to the scope and context of each project. Using existing Nexvision modules, the time to market is reduced significantly with respect to the classical process.

" The Nexvision Quality Management System is based on the requirements of the international standards ISO 9001:2015 and EN 9100:2016. "



PRODUCTS COMPLYING WITH MILITARY AND AERO STANDARDS

MIL-STD
785B

MIL-STD
810

RTCA DO
160

STANAG
4370

ARP
4754a

RTCA DO
178

RTCA DO
254

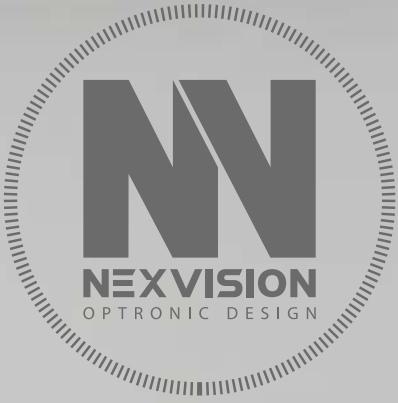

AN INTERNATIONAL COMPANY



● FRANCE (headquarter)

● USA

● MOROCCO

● BULGARIA

● INDIA

● SOUTH KOREA

MORE ABOUT NEXVISION

www.nexvision.fr

.....

TO ORDER OUR PRODUCTS

sales@nexvision.fr

[+33] 4 91 77 62 86

